

# Standard Industrial Eliminator Blade Separator

VentilationComponents.com's  
eliminator blade separators are  
durable and cost effective.

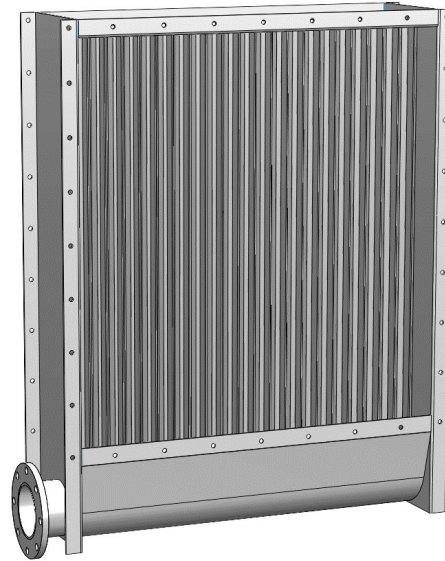

## Application

- Removes mist from an airstream.
- Horizontal air flow
- Various sizes built to service airflows ranging from 10,600cfm to 90,000cfm available, with larger sizes available upon request
- Pressure ratings ranging from 15inWC to 50inWC available, with higher pressure ratings up to 100inWC available upon request

## Features

- Vertical eliminator blade separator
- Flanged inlet and outlet
- Integral sump and drain

## Benefits

- Compact design
- Uses intermittent cleaning water system for reduced water consumption
- Simple, reliable, and easy to maintain
- Heavy duty construction

## Function

- Air flows through passages between the blades
- Droplets are caught in extended lips at each corner
- The droplets flow downwards to the sump below

## Options

### Capacity

Nominal capacities ranging from 10,600cfm to 90,000cfm at 1,000fpm face velocity are available. Larger sizes are available upon request.

### Pressure rating

Three different pressure ratings are offered: 15inWC, 30inWC, and 50inWC. Custom pressure ratings up to 100inWC are available upon request.

### Flange bolt pattern

The flange bolt patterns follow our standard. Different patterns are available upon request.

### Materials

The materials offered suit a variety of applications.

#### Internal material

- 316 stainless steel

Other materials not listed are available upon request.

### Efficiency Rate

The efficiency of the separator is application dependent and is provided during the ordering stage.

### Data and dimensions

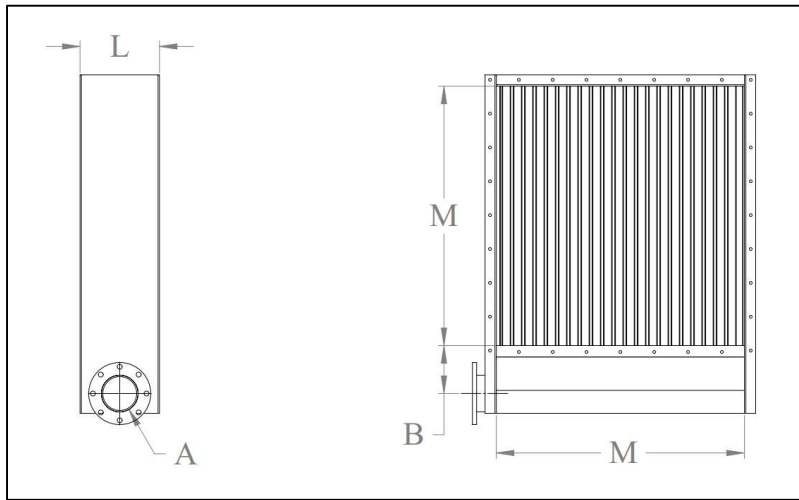

Item Number	"M" Largest Dimension Width or Height		Nominal Pressure Rating	"L" Length	"A" Drain Size	"B"
	M <sub>LOWER</sub>	M <sub>UPPER</sub>				
	inches	inches	inWC	inches	nominal pipe	inches
DS-04-[36.00 to 39.00]-15	36.00	39.00	15	9.50	P6	8.75
DS-04-[36.00 to 39.00]-30	36.00	39.00	30	9.50	P6	8.75
DS-04-[36.00 to 39.00]-50	36.00	39.00	50	9.50	P6	8.75
DS-04-[39.01 to 46.00]-15	39.01	46.00	15	10.00	P6	8.75
DS-04-[39.01 to 46.00]-30	39.01	46.00	30	10.00	P6	8.75
DS-04-[39.01 to 46.00]-50	39.01	46.00	50	10.00	P6	8.75
DS-04-[46.01 to 48.00]-15	46.01	54.00	15	11.00	P6	8.75
DS-04-[46.01 to 48.00]-30	46.01	54.00	30	11.00	P6	8.75
DS-04-[46.01 to 48.00]-50	46.01	54.00	50	11.00	P6	8.75
DS-04-[54.01 to 62.00]-15	54.01	62.00	15	12.50	P6	8.75
DS-04-[54.01 to 62.00]-30	54.01	62.00	30	12.50	P6	8.75
DS-04-[54.01 to 62.00]-50	54.01	62.00	50	12.50	P6	8.75
DS-04-[62.01 to 70.00]-15	62.01	70.00	15	13.00	P6	8.75
DS-04-[62.01 to 70.00]-30	62.01	70.00	30	13.00	P6	8.75
DS-04-[62.01 to 70.00]-50	62.01	70.00	50	13.00	P6	8.75
DS-04-[70.01 to 78.00]-15	70.01	78.00	15	13.75	P8	11.50
DS-04-[70.01 to 78.00]-30	70.01	78.00	30	13.75	P8	11.50
DS-04-[70.01 to 78.00]-50	70.01	78.00	50	13.75	P8	11.50
DS-04-[78.01 to 86.00]-15	78.01	86.00	15	14.75	P8	11.50
DS-04-[78.01 to 86.00]-30	78.01	86.00	30	14.75	P8	11.50
DS-04-[78.01 to 86.00]-50	78.01	86.00	50	14.75	P8	11.50
DS-04-[86.01 to 94.00]-15	86.01	94.00	15	16.00	P8	11.50
DS-04-[86.01 to 94.00]-30	86.01	94.00	30	16.00	P8	11.50
DS-04-[86.01 to 94.00]-50	86.01	94.00	50	16.00	P8	11.50
DS-04-[94.01 to 101.00]-15	94.01	101.00	15	17.50	P8	11.50
DS-04-[94.01 to 101.00]-30	94.01	101.00	30	17.50	P8	11.50
DS-04-[94.01 to 101.00]-50	94.01	101.00	50	17.50	P8	11.50
DS-04-[101.01 to 108.00]-15	101.01	108.00	15	19.00	P10	14.00
DS-04-[101.01 to 108.00]-30	101.01	108.00	30	19.00	P10	14.00
DS-04-[101.01 to 108.00]-50	101.01	108.00	50	19.00	P10	14.00
DS-04-[108.01 to 120.00]-15	108.01	120.00	15	21.00	P10	14.00
DS-04-[108.01 to 120.00]-30	108.01	120.00	30	21.00	P10	14.00
DS-04-[108.01 to 120.00]-50	108.01	120.00	50	21.00	P10	14.00

Notes

1. 3D model files and general arrangement drawings with installation details available upon order.
2. Nominal capacity is based upon 1,000fpm face velocity and can be provided upon request.

### Standard rectangular flange details

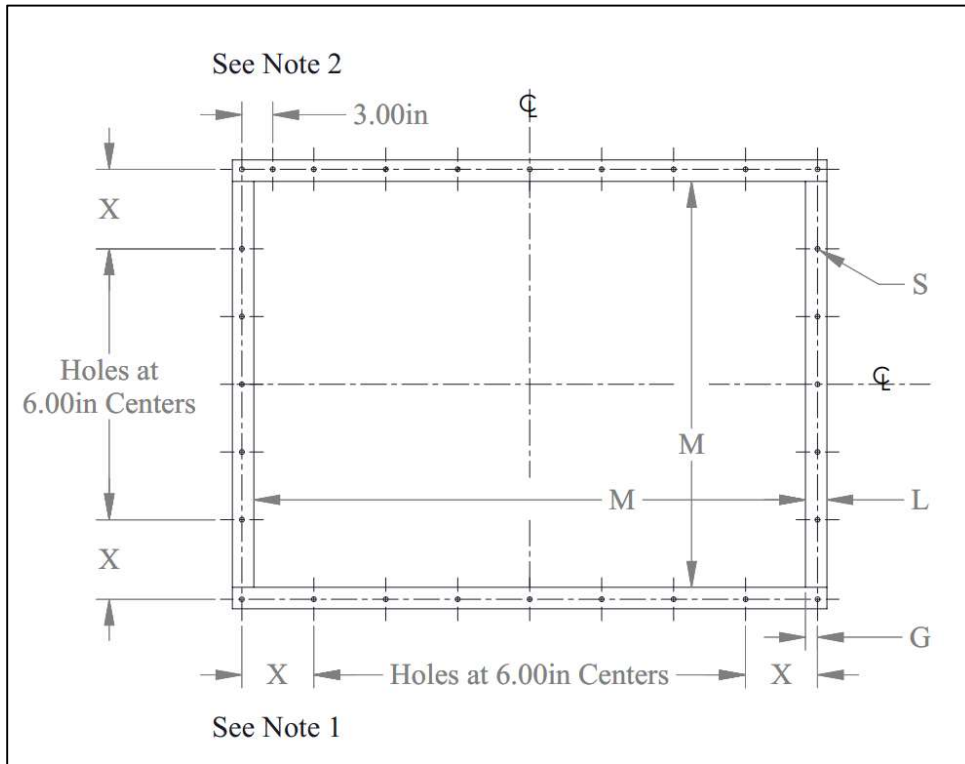

"M" Largest Dimension Width or Height		"L" Flange Leg	"G" Gauge	"S" Hole Diameter	Bolt Size
M <sub>LOWER</sub>	M <sub>UPPER</sub>				
inches	inches	inches	inches	inches	inches
0	31.00	1.50	0.875	0.500	3/8
31.01	39.00	2.00	1.125	0.500	3/8
39.01	78.00	2.50	1.375	0.625	1/2
78.01	101.00	3.00	1.750	0.625	1/2
101.01	120.00	4.00	2.250	0.625	1/2

Notes

1. "X" is minimum 2.50in and maximum 8.50in.
2. If "X" is greater than 6.00in, add an extra hole 3.00in from corner hole.
3. Holes always land on centerlines and corners.

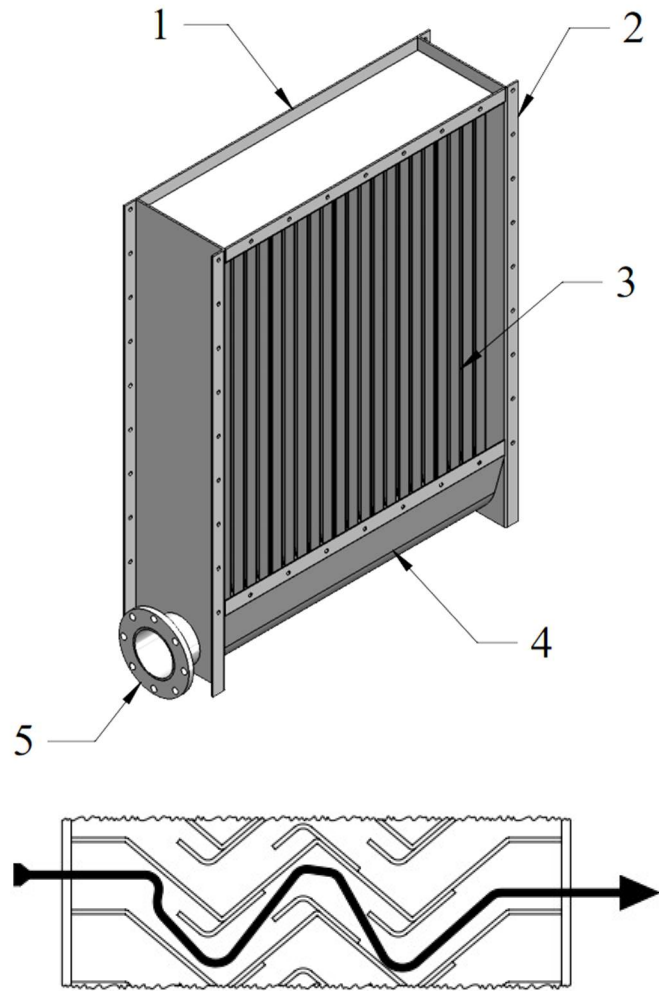

Parts list

Number	Quantity	Description
1	1	Inlet
2	1	Outlet
3	Varies	Eliminator blade
4	1	Sump
5	1	Drain

Notes

1. All hardware provided, unit is assembled when delivered.

## How to order

To fully specify the DS-04 Eliminator Blade Separator, make a selection from the code boxes below.

**Example:** DS-04-C-1-30-S, shown below, is an eliminator blade separator with 316 stainless steel as the primary material, a 30inWC pressure rating, and our standard bolt pattern. The customer has specified that the separator be 36.00in height and 80.00in width. At 1,000fpm, the nominal capacity of an eliminator blade separator this size would be 20,000cfm.

1	2	3	4	5	6
DS	04	C	1	30	S
Specifications					
Please provide a drawing for our approval of a 36.00in height and 80.00in width set of eliminator blades, as specified.					

1	Equipment type				
DS	Droplet Separator				
2	Equipment sub-type				
04	Eliminator Blades				
3	Capacity				
C	Customer Specified Size				
4	Primary material				
1	316 Stainless Steel	C	Customer Specified Material		
5	Pressure rating				
15	15inWC, Up to 1000fpm	50	50inWC, Up to 1000fpm		
30	30inWC, Up to 1000fpm	C	Customer Specified Pressure Rating		
6	Flange bolt patterns				
S	Standard	C	Customer Specified Flange Bolt Pattern		

Many types of customizations are available upon request.

**Note:** There are various factors which should be considered when selecting a droplet separator for a specific application. Some of these factors are outside of the scope of this data sheet. If you have any questions regarding the application, compatibility, or use of this droplet separator, contact [VentilationComponents.com](http://VentilationComponents.com) for more information.





Contact@VentilationComponents.com